

PROFITABLE FSW-SOLUTIONS

FOR YOUR PRODUCTION PROZESS.

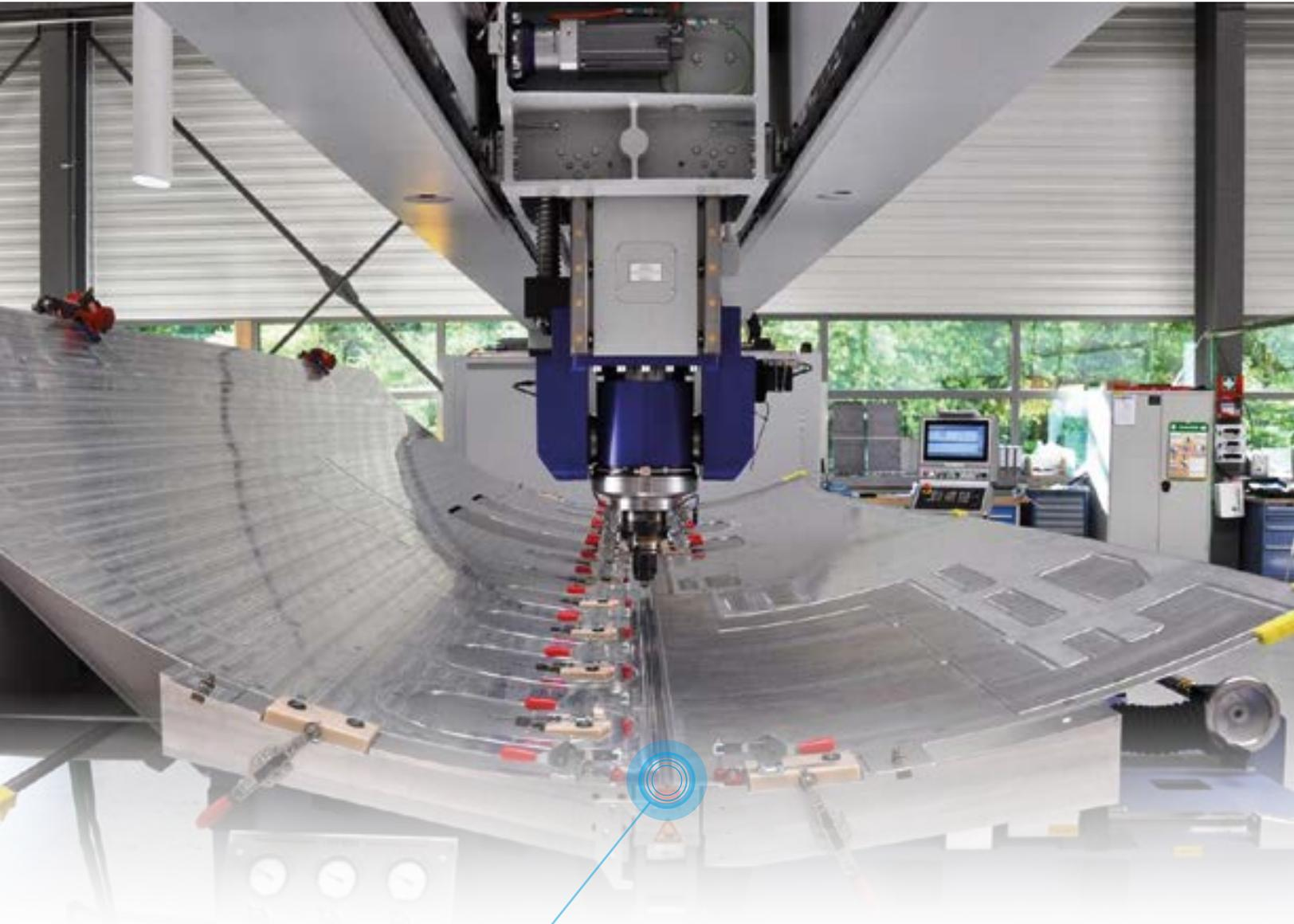

FRICITION STIR WELDING

STRONG JOINTS FOR THE INDUSTRY.

STRONG JOINTS FOR THE INDUSTRY

Quality „made in Germany“: this philosophy is consistently followed by FOOKE.

Are you a partner of the industry and are facing the challenge of reliably welding large components in constant quality? In that case, the technology of friction stir welding offers you key advantages.

With modular machine systems, FOOKE provides process reliable overall solutions for the automatic manufacturing. We use our know-how and experience as long-time manufacturer of gantry milling machines and from numerous applications in the railway technology, the automotive and the aerospace industry, for the development of innovative machine concepts in the field of FSW.

From individual FSW systems up to a completely new interlinked manufacturing process, we supply overall FSW solutions for the industrial series production. Many years of experience in mechanical engineering, joining technology and our high in-depth production translate into efficient machine concepts, specially tailored to your needs.

Our turnkey solutions guarantee an optimized productivity and a high level of safety and reliability – worldwide. Discover new markets with our innovative FSW solutions!



EXPERTISE IN FSW

Benefit from our turnkey process:

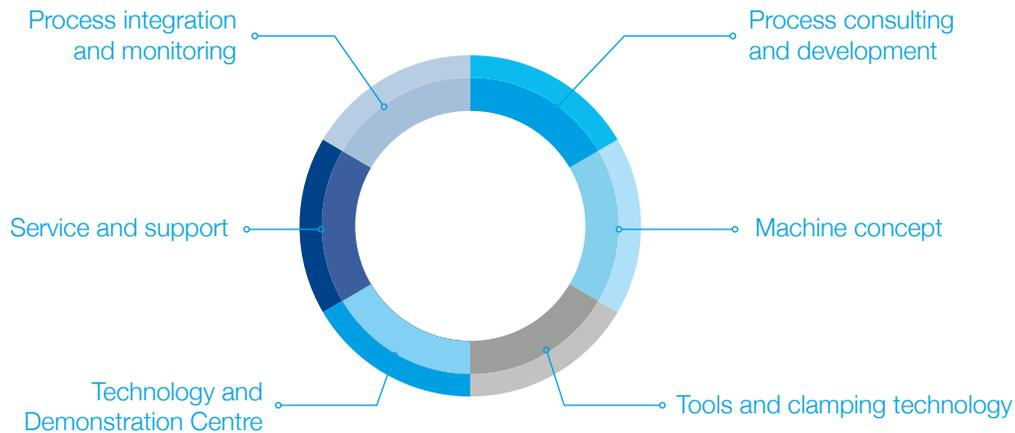

From process consulting and development to production and commissioning, we carry out all processes for you.

Our customised individual solutions in combination with an established system of standard components, assemblies and clamping concepts ensure an effective machine concept that you can easily and efficiently use when you take over.

In order to develop optimum parameters for your production, we carry out feasibility studies for your component in our Technology and Demonstration Center in advance.

After the acceptance, we remain at your disposal with product support, process optimization, training and service. Fast response times, an extensive spare parts warehouse and worldwide service ensure the productivity of your plant.

Our know-how for your process:

- Many years of experience in mechanical engineering.
- High vertical range of manufacture including tool development, joining and clamping technology.
- Turnkey-Solutions: solutions from one source.
- Comprehensive and worldwide service and fast help on site.



INDUSTRY



MATERIAL SELECTION



YOUR REQUIREMENTS



YOUR REQUIREMENTS DETERMINE OUR SOLUTION

We do not offer off-the-shelf FSW solutions because your machines must interact with specific processes in an individual environment.

Before we develop your machine concept, we analyse your production process: Which materials are used, how is the surrounding production designed, what demands do you have on your components and what are your quality requirements? All this knowledge is the basis for your FOOKE FSW team.

We only start development once we have established the relevant parameters in advance. We always remain in close contact with you.

Our development team guides you through the entire process: from the machine to the software and maintenance, we provide solutions that are perfectly adapted to your needs.

Your advantages at a glance:

- Detailed consultation in advance.
- Intensive exchange with our FSW engineers.
- Modular machine structure enables individual adaptability of the FSW systems.
- Best possible integration into existing production processes.
- High return of investment.



INDIVIDUAL
WELDING STRATEGIES

INTEGRATION INTO YOUR PROCESSES

SHORTER PROCESSING TIMES AND FULLY AUTOMATIC PROCESS ASSURANCE

Friction stir welding opens completely new areas of welding technology.

With FSW technology, fast and high-quality welded joints are easily possible.

The process of friction stir welding connects two workpieces by a rotating, specially designed tool. The welding pin dips into the material of the workpieces. The resulting rotation and the applied pressure generate frictional heat, which makes the material malleable. The workpieces are stirred together without filling or additional material and a homogeneous mixture is created along the joining line.

After cooling, the two workpieces are joined in a solid-phase connection - without welding defects such as pores or cracks. You avoid expensive reworking and achieve high, reproducible weld seam qualities due to the process reliability in the welding process.

Benefit from the advantages of Green Technology: low energy consumption and a low-vibration, low-noise and low-emission mode of operation that requires no fume extraction or glare protection measures and generates no optical radiation.

The friction stir welding process:

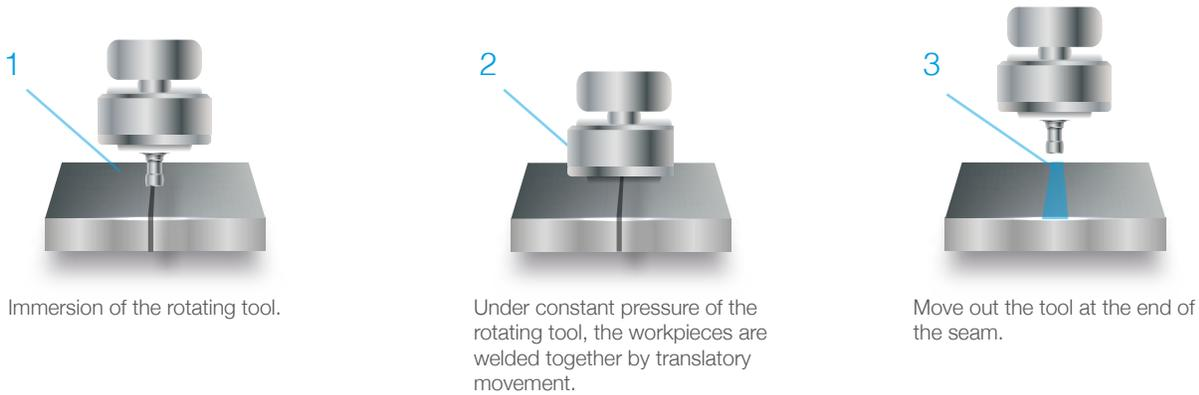

ECONOMIC PRODUCTION

HIGHEST WELDING QUALITY

ADVANTAGES THAT PAY OFF FOR YOU



* Source: Dissertation by Markus F. Ruhstorfer, 14.06.2012
Faculty of Mechanical Engineering, Technical University Munich

Advantages of the process:

- Different material combinations possible.
- One-sided welding of thicker sheets up to 50 mm
- Low process temperatures, low residual stresses and thus little distortion.
- Excellent mechanical properties.
- High productivity due to low pre/reworking of the weld seam.
- No filler materials and auxiliary materials necessary.
- Green Technology.
- Very high reproducibility.
- Good quality control thanks to fully automatic process monitoring.
- Homogeneous, dense seam areas without porosity and inclusions.

GOOD RESULTS CERTAINLY ACCHIEVED

Your optimized component is the goal of our process.

We accompany you from the first consultation, parameter development, test welding and machine implementation to process monitoring. We document the entire process and compile significant data that provide the basis for a reproducible welding process.

In close cooperation with you, we develop the optimum machine solution for your component and your production processes. Extensive experience and the application of virtual planning methods such as CAD planning, material flow simulation, collision control, 3D laser scanning processes and virtual commissioning enable us to develop individual concepts that meet your requirements in terms of efficiency, interface optimization, sustainability and productivity.

Our services include materials consulting, adapting the geometry of your profiles to the requirements of FSW welding and developing a specific welding strategy.

Our process does not end with the delivery of the machine. Beyond commissioning, we ensure that the machine is safely integrated into your processes. In individual FSW training courses we familiarize you with the applicable standards, parameters, testing requirements and demands on companies.

We not only instruct your employees in machine operation, but also show them the possibilities of the machine and the welding process, develop ideas for new production possibilities and discover potentials. This way your employees are actively involved and become part of the innovative development.

The process chain:

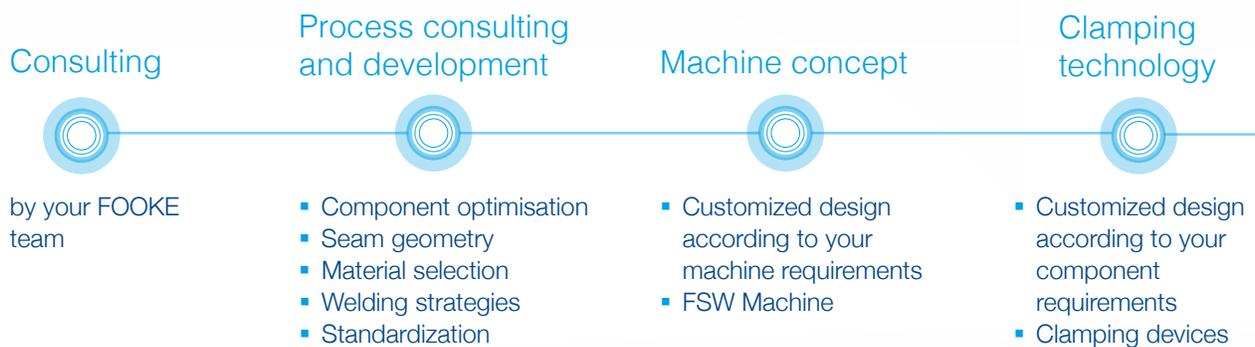

Benefits of our process:

- Continuous monitoring of the process.
- Customized design of the machine for your requirements.
- Safety through validated processes in our technology and demonstration center.
- Component optimisation including profile adaptation.
- Development of intelligent welding strategies.
- Weld control for quality assurance.
- Training and involvement of your employees for optimal integration of the machine.

Tools



- Design of optimum tool geometry
- Parameter determination
- Selection of suitable materials

Application Center



- Preliminary tests and evaluation
- Tests
- Preliminary investigations

Process consulting and development



- Introduction and monitoring of the process
- Weld-Control: Documentation of data for quality assurance

Your optimized component



WELD LARGE PARTS WITH FLYING EASE IN AVIATION

The challenge for the aerospace industry is to produce as light, strong and cost-effective as possible.

FSW is an innovative manufacturing process for the production of integral fuselage structures: The promising substitution of the riveting process by efficient welding processes such as friction stir welding offers clear advantages in terms of cost and weight savings.

The quality requirements for materials are particularly high in aerospace and aircraft construction: tropical heat on the ground, icy cold at high altitudes. They must be able to maintain the air pressure in the cabin, expand or stretch within defined limits and contract again without forming cracks or holes. There are no compromises in terms of safety. This gives modern materials and production processes a special significance.

Innovative designs of metallic lightweight components in the field of airframes, interior fittings or air freight containers can significantly reduce assembly lead times and thus strengthen the competitiveness within the aerospace industry.

The processing of aluminium also plays an important role in the design of space probes, launchers and fuel tanks and offers many possibilities for the use of FSW technology.

Your advantages in the aerospace industry:

- Weight savings with the elimination of rivets and a different stiffening technology.
- Pressure and vacuum-tight connections.
- Improved corrosion resistance due to gap-free joints and no rivet holes.
- Reliable connection of large aircraft components.
- Cost reduction through high degree of automation.
- High production speed.



WING COMPONENTS

STRINGER PROFILES

SKINS

CARRIERS

CONNECTION CONSOLES

FUEL SYSTEMS

BOOSTER



Your benefits in vehicle construction:

- High quality connection of lightweight materials.
- Processing of innovative material concepts.
- Reproducibility of high seam qualities.
- Low distortion.
- Very high seam qualities.
- Pressure- and helium-tight joints.
- High crash safety.

BEARING HOUSING

GEARBOX HOUSING



STEP UP THE PACE WITH WELDING IN AUTOMOTIVE ENGINEERING

Wide range of possibilities for process-safe joining of different materials.

In order to keep the vehicle weight low, the use of aluminium alloys is particularly suitable in the automotive industry.

FSW welding is a cost-effective manufacturing process for joining lightweight structures. There are many areas of application in the automotive industry: In the series production of aluminium components, a friction stir welded centre tunnel, as a load-bearing component, increases the rigidity of the chassis.

With the help of FSW, for example, tie rods and rim strips as well as exhaust valves for combustion engines are welded in large quantities. In the field of e-mobility, cast aluminum is increasingly used for battery trays.

Friction stir welding is also already being used efficiently for other production areas within the automotive industry.

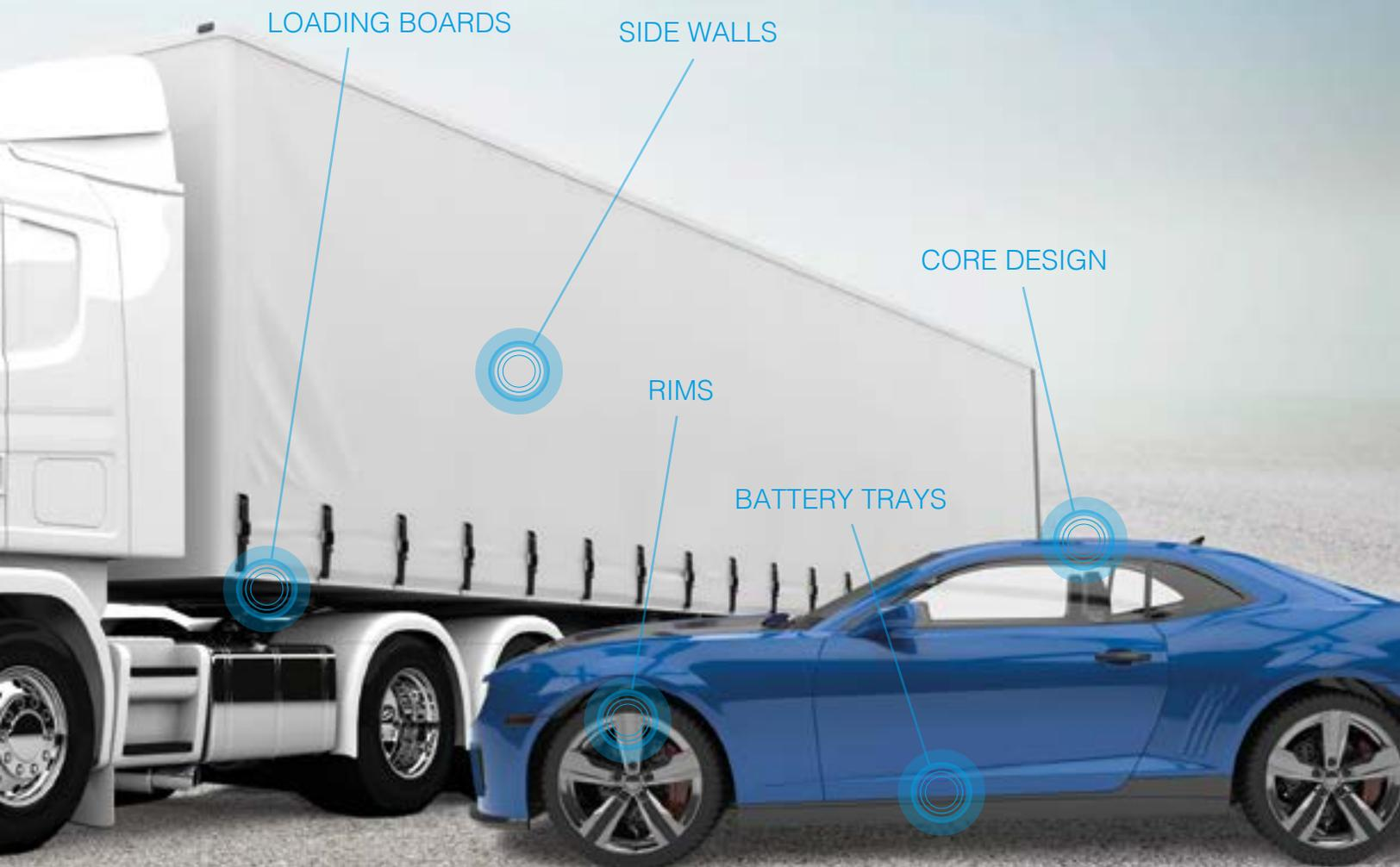

Your benefits in the rail industry:

- High mechanical load capacity.
- Low distortion.
- High crash safety.
- Lightweight construction with the use of extruded aluminium profiles.
- High degree of automation.
- Large wall thicknesses weldable in one layer.



MAIN
LONGITUDINAL
BEAM

FLOOR
ASSEMBLIES

SIDE WALLS

SWITCH TO HIGH SPEED IN RAIL VEHICLE CONSTRUCTION

FSW enables better seam qualities and less rework.

In rail vehicle construction, the use of extruded aluminium profiles for the production of side panels, roof panels and floor panels has proven its worth. Initially, these profiles are welded together to form side walls, roof and floor panels which eventually are being joined to form a car body. Main longitudinal beams and floor panels of electric railcars are also welded with FSW.

The complete side walls for the trains of the London Underground are already made out of FSW panels.

The process of FSW welding of aluminium components ensures low distortion and high crash safety with simultaneous weight savings.

ROOFING GROUPS



MOTOR SUPPLIES



OFFSHORE MODULES

MODULES AND STAIR
TOWER WALLS

SHIP DECKS

SIDE WALLS

FRIGHT TANKS



GO BIG IN SHIPBUILDING

Connect large components in naval engineering.

Large FSW systems accomplish this in the shipyards by prefabricating the outer skin, decks and bulkheads. A reliable, reproducible welding process is the best guarantee for durability and quality in shipbuilding.

Every weld seam must be right on target: After all, these ships sail the world's oceans for 25 years or more and must not only withstand rain and salt water, but also the various mechanical stresses caused by wind and the movement of the waves.

FSW welding is particularly suitable for aluminium alloys in the area of ship superstructures or for the steel-aluminium transition between deck and deck superstructure. The process could thus replace the variants with bolts or explosive-welded T-pieces that are usually used for the steel-aluminium transition in shipbuilding.



ELEVATOR SHAFTS

YACHT CONSTRUCTIONS

Your benefits in shipbuilding:

- Weather-resistant connection due to the absence of rivets.
- Reduction of manufacturing costs in the construction of lightweight structures for ship assemblies.
- Possibilities of material thickness reduction.
- Large wall thicknesses can be welded in one layer.
- Multiple sheet metal connections possible.

THINK BIG IN INDUSTRIAL PLANT CONSTRUCTION

Numerous application areas of the FSW process in industrial plants.

Your tasks are silo construction, tank construction and aluminium constructions in the fields of chemistry, petrochemistry, plastics, food, energy and environmental technology? Here, tightness is indispensable: especially for constructions and components such as heat exchangers, battery

trays or coolers. Long-term, solid, media- and pressure-tight connections between workpieces are a must. FSW finds application in the field of crane components, facade panels, heat sinks, silos and scaffolding.

SCAFFOLDING

REFRIGERATORS





Your benefits in industrial plant construction:

- High flexural strength.
- Increase of the effective load.
- Increased durability and stability of the joints.
- Significant weight savings.
- Pressure-tight connections.



CRANE COMPONENTS



SILOS



FRONT PANELS

INDIVIDUAL TOOLS AND CLAMPING SYSTEMS ENSURE QUALITY AND SPEED

The welding tool adapted to your component and material is decisive for friction stir welding.

To ensure quality, we develop tools optimised for process speed or wear resistance and work out the suitable seam geometry and parameters for you.

The adaptation of the friction pin and shoulder materials as well as the tool geometry to your production process ensures a more efficient heat generation, increases the welding speed and ensures better seam and seam surface quality. You can change the tool automatically.

Any FSW process is only as good as the fixture holding the part. That is why we develop clamping systems specially adapted to the workpieces in the form of hardtoolings or universal „MultiTooling clamping devices“.

These take up and absorb the high process forces. This way, your workpiece is supported and aligned with low deformation. This ensures clean results and compliance with tight tolerances.

Our modular clamping technology allows you to join components of almost any length. You can choose between manual execution, partial or full automation.

In order to provide state of the art tools and process technology, we work closely with institutes.

Our expertise:

- Design of optimal tool geometry.
- Parameter determination.
- Selection of suitable materials.
- Experience in clamping devices of any kind.
- Individual clamping concepts in partial or full automation.



PROCESS-SPECIFIC TOOLS



FLEXIBLE CLAMPING SYSTEM

FULLY AUTOMATIC POSITIONING

SCALABLE FOOKE FSW MACHINES: AS INDIVIDUAL AS YOU

Thanks to our modular design, we supply machines in any size and for any application.

You will be supplied with the machine size that suits your production requirements best: Our offer ranges from 3-axis up to 5-axis machines.

You can equip our machines with both welding and milling heads, enabling you to perform a complete machining operation with little changeover time on one machine. This guarantees a good workload and short downtimes.

Specific clamping concepts like manual or fully automatic versions are an essential part of the machine equipment.

FOOKE FSW systems are designed for very high process forces at maximum stiffness. Our specially developed sensor system also guarantees you the highest process reliability in the welding process.



„A great advantage for you is that we can build the FSW machine exactly to your needs with our modular design. In addition, thanks to the hybrid design, you can both weld and mill with our machines. This offers you versatile application possibilities and guarantees a reasonable return on investment.“

Christian Wanising, FSW Development Engineer



Your benefit:

- Very rigid machine system.
- Machine and system scalability.
- Maximization of utilization through hybrid design.
- Individual clamping concepts.
- Process-optimised FOOKE sensor system.

FSW Overview

FOOKE
FSW Small



FOOKE
FSW 10



FOOKE
FSW Medium



FOOKE
FSW 20



FOOKE
FSW Large



FOOKE
FSW 30



FOOKE FSW Heads and Spindles

We have a large number of welding heads and welding spindles in our portfolio. Our heads and spindles are available with all options, this includes:

- Milling / Deburring
- Friction stir welding with standing shoulder
- Retractable pin tool
- Bobbin tool welding
- Lighting
- Camera connection
- Active tool cooling
- Pressing devices
- Automatic tool change
- Friction Spot Welding
- further head kinematics possible (AC, or AB kinematics)

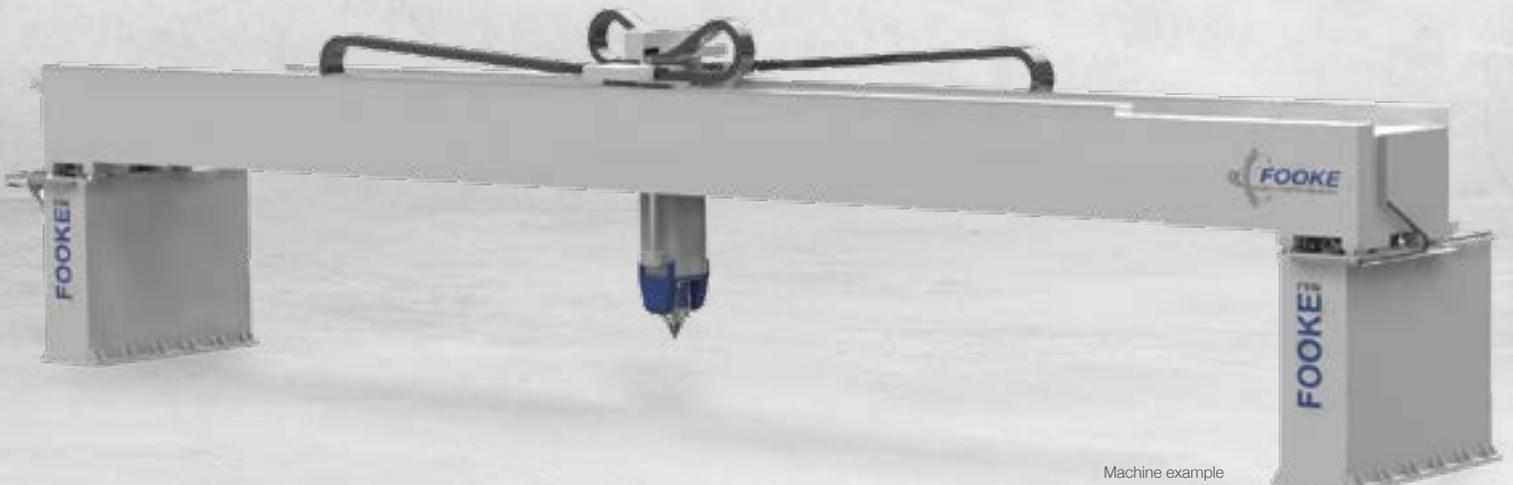

Machine example

FOOKE FSW SMALL: FOR SIMPLE WELDING SEAMS ON PLANE SURFACES

The versatile basic model.

FOOKE FSW Small series is a machine tool for the machining of smaller components in the automotive industry, rail technology, aerospace, heat exchangers and many more. It allows you to easily produce simple welding seams on plane surfaces with sheet thicknesses of up to 1.57" at high axial forces and torques for almost any application.

This machine type is easy to operate and is characterized by good handling. This makes it perfect as an entry-level model but also suitable for small series production.

SHEET THICKNESSES UP TO 1.57"

1-AXIS OPERATION



Technical data

	Strokes	Feed rates
X axis:	39.4" - 3,543.3" (1,000 - 90,000* mm)	1,574.8"/min (40,000 mm/min)
Y axis:	up to 236.2" (up to 6,000 mm)	1,574.8"/min (40,000 mm/min)
Z axis:	up to 98.4" (up to 2,500 mm)	393.7"/min (10,000 mm/min)

* Other travel lengths also available on customer request.

Welding parameters

Welding depth:	up to 1.57" (40 mm)
Max. axial force:	up to 11.240 lbf (50 kN)
Welding feeds:	up to 236.2"/min (6,000 mm/min)



MACHINING OF
SMALLER COMPONENTS

Options:

- Milling.
- Friction stir welding with standing shoulder.
- Retractable pin tool.
- Bobbin tool welding.
- Friction spot welding.

Features:

- Force control.
- Distance control.
- Weld seam tracking.
- GAP measurement.
- FOOKE Weld Control.
- Free NC programming.

Your benefits:

- FSW tool development.
- Stable FSW process.
- High, reproducible weld-seam quality.

FOOKE FSW MEDIUM: THE FLEXIBLE ALL-ROUNDER FOR ALMOST EVERY APPLICATION

Hybrid machining of large-scale workpieces.

FOOKE FSW Medium series offers machine tools for the hybrid processing of large-scale workpieces of low-melting metals, especially manufactured for friction stir welding of profiles, used in the rail vehicle, aerospace, shipbuilding and automotive industries.

High process forces generated during friction stir welding require a highly rigid machine structure. This is why the machines in the FOOKE FSW Medium series are designed for very high loads and at high stiffness levels. They are preferably used for joining thick sheets and profiles with 2D contours.

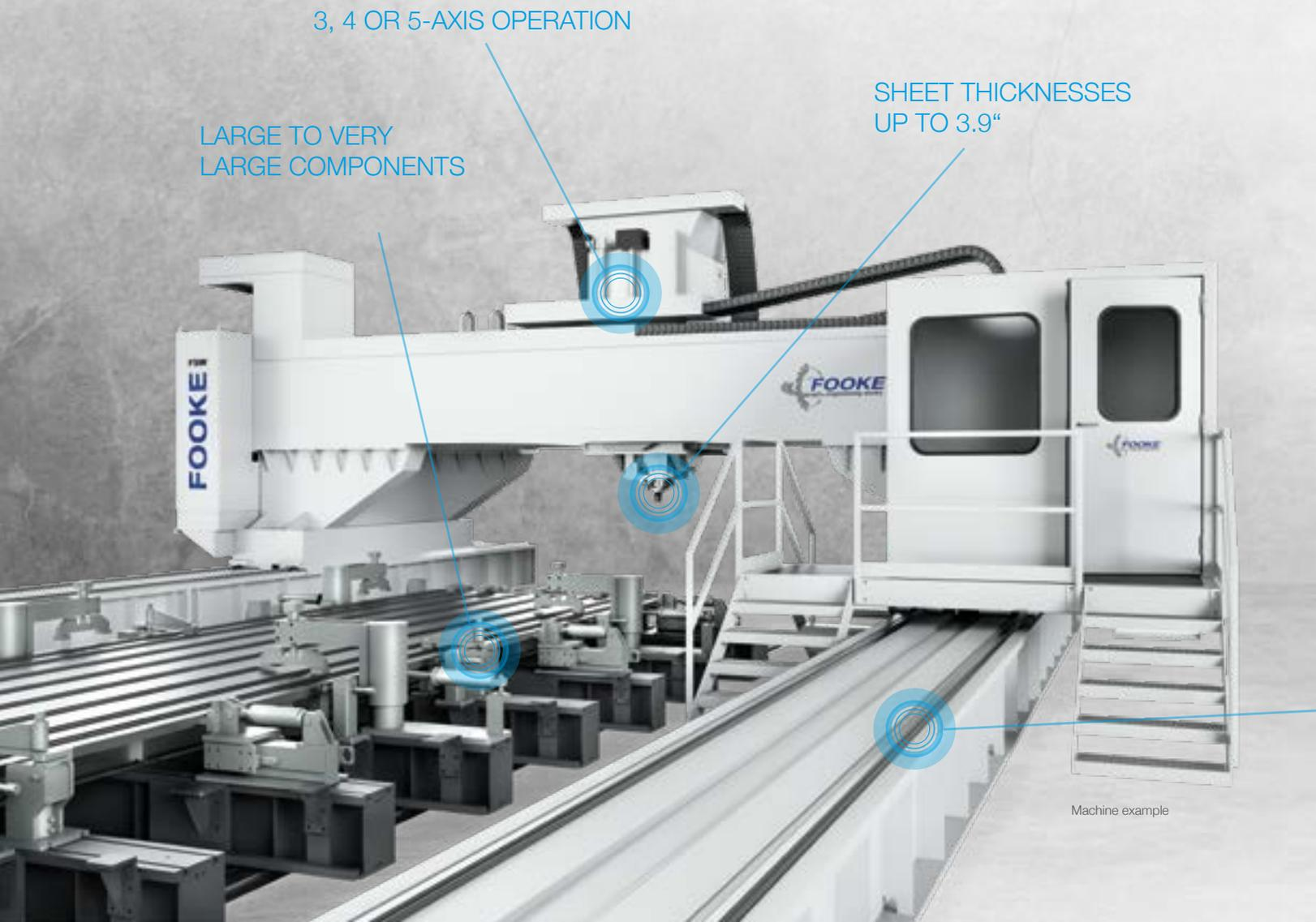

Machine example

Technical data

	Strokes	Feed rates
X axis:	39.4" - 3,543.3" (1,000 - 90,000* mm)	1,574.8"/min (40,000 mm/min)
Y axis:	up to 236.2" (up to 6,000 mm)	1,181.1"/min (30,000 mm/min)
Z axis:	up to 98.4" (up to 2,500 mm)	393.7"/min (10,000 mm/min)

* Other travel lengths also available on customer request.

Welding parameters

Welding depth:	up to 2.75" (70 mm)
Max. axial force:	up to 22.481 lbf (100 kN)
Welding feeds:	up to 236.2"/min (6,000 mm/min)

HIGH AXIAL FORCES
AND TORQUES

Options:

- Milling.
- Friction stir welding with standing shoulder.
- Retractable pin tool.
- Bobbin tool welding.
- Friction spot welding.

Features:

- Force control.
- Distance control.
- Weld-seam tracking.
- GAP measurement.
- FOOKE Weld Control.
- Free NC programming.

Your benefits:

- FSW tool development.
- Stable FSW process.
- High, reproducible weld-seam quality.

FOOKE FSW LARGE: EFFECTIVE MACHINING OF LARGE COMPONENTS

Friction stir welding with process forces.

Our standardised FOOKE FSW Large series offers machine tools for hybrid machining of large to very large components in the aerospace, rail vehicle, shipbuilding and many more sectors.

You can easily weld sheet thicknesses of up to 3.9" with these machines. Travel speeds of up to 787.4"/min prevent unnecessary loss of time during empty runs.

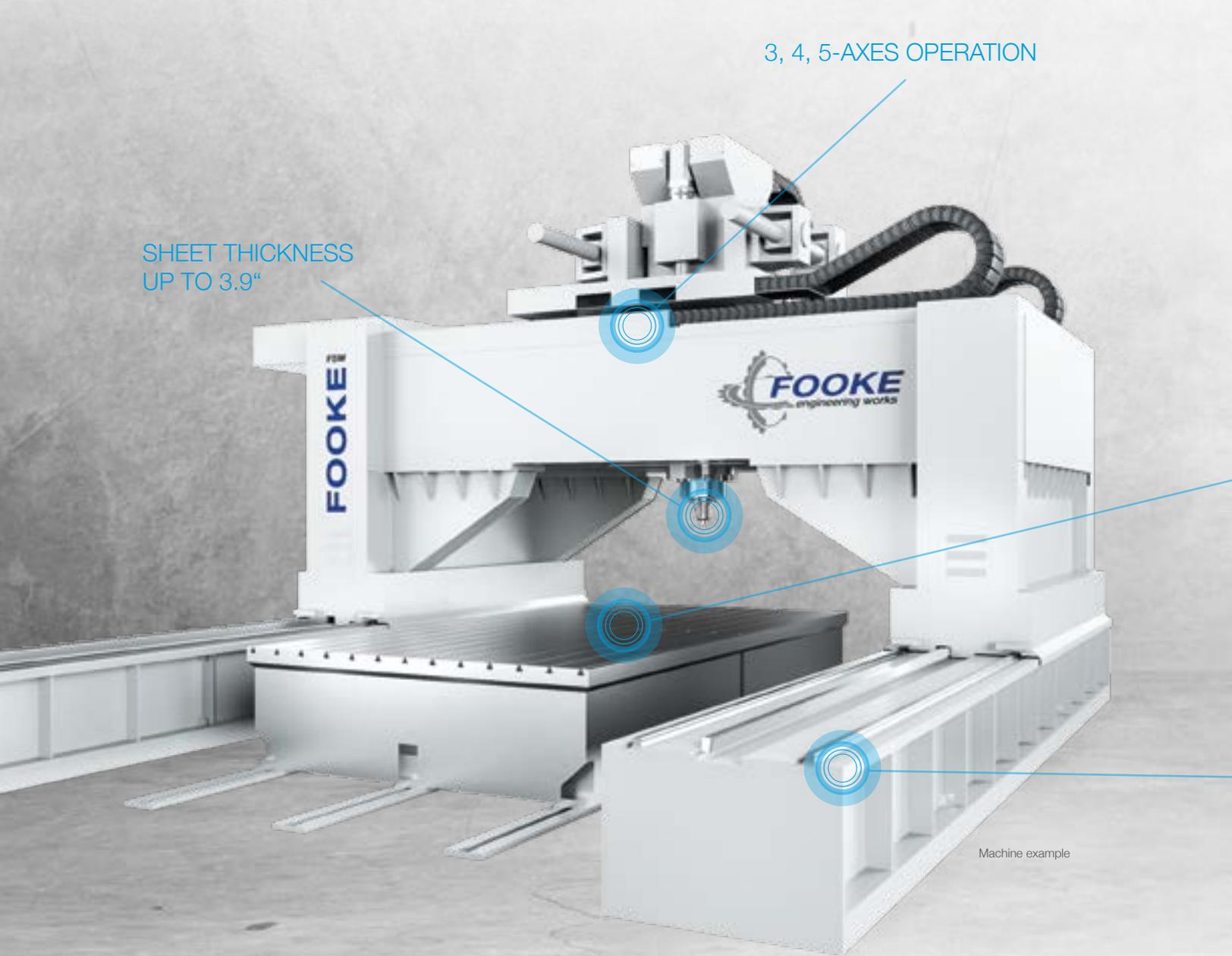

SHEET THICKNESS
UP TO 3.9"

3, 4, 5-AXES OPERATION

Technical data

	Strokes	Feed rates
X axis:	39.4" - 3,543.3" (1,000 - 90,000* mm)	787.4"/min (20,000 mm/min)
Y axis:	up to 236.2" (up to 6,000 mm)	787.4"/min (20,000 mm/min)
Z axis:	up to 98.4" (up to 2,500 mm)	393.7"/min (10,000 mm/min)

* Other travel lengths also available on customer request.

Welding parameters

Welding depth:	up to 3.9" (100 mm)
Max. axial force:	up to 44.962 lbf (200 kN)
Welding feeds:	up to 236.2"/min (6,000 mm/min)

SMALL AND MEDIUM-SIZED COMPONENTS

LOAD AND TEMPERATURE SYMMETRICAL DESIGN

Options:

- Milling.
- Friction stir welding with standing shoulder.
- Retractable pin tool.
- Bobbin tool welding.
- Friction spot welding.

Features:

- Force control.
- Distance control.
- Weld-seam tracking.
- GAP measurement.
- FOOKE Weld Control.
- Free NC programming.

Your benefits:

- FSW tool development.
- Stable FSW process.
- High, reproducible weld-seam quality.

FOOKE FSW 10 FRICTION STIR WELDING SYSTEM

Universal 3-axis Friction Stir Welding Machine for the Production of Linear Welds

The FOOKE FSW 10 is a 3-axis machine tool for linear friction stir welding of aluminum workpieces or similar materials. It represents an optimal entry into the technology of friction stir welding.

Machine design

The structural components of the FOOKE FSW 10 are manufactured as extremely rigid, stress-relieved welded steel construction. The linear axes are equipped with hardened and ground linear guide elements and driven by pinion-rack (X-axis) or recirculating ball screw (Y- and Z-axis).

Control

The FOOKE FSW control system enables a simple and intuitive operation. The user interface is user-friendly, clearly displaying all important information and ensuring optimum control of the welding process.

All relevant parameters can easily be set up on the panel, e.g.

- welding force,
- rpm,
- welding speed,
- traverse paths,
- etc.

FOOKE FSW force sensor system

The FOOKE FSW force sensor system consists i.a., of a sensor unit integrated into the FSW spindle, which measures the axial force generated in the welding process. This ensures a constant force within certain limits to guarantee a consistent, optimum quality of the weld seam, at all times.

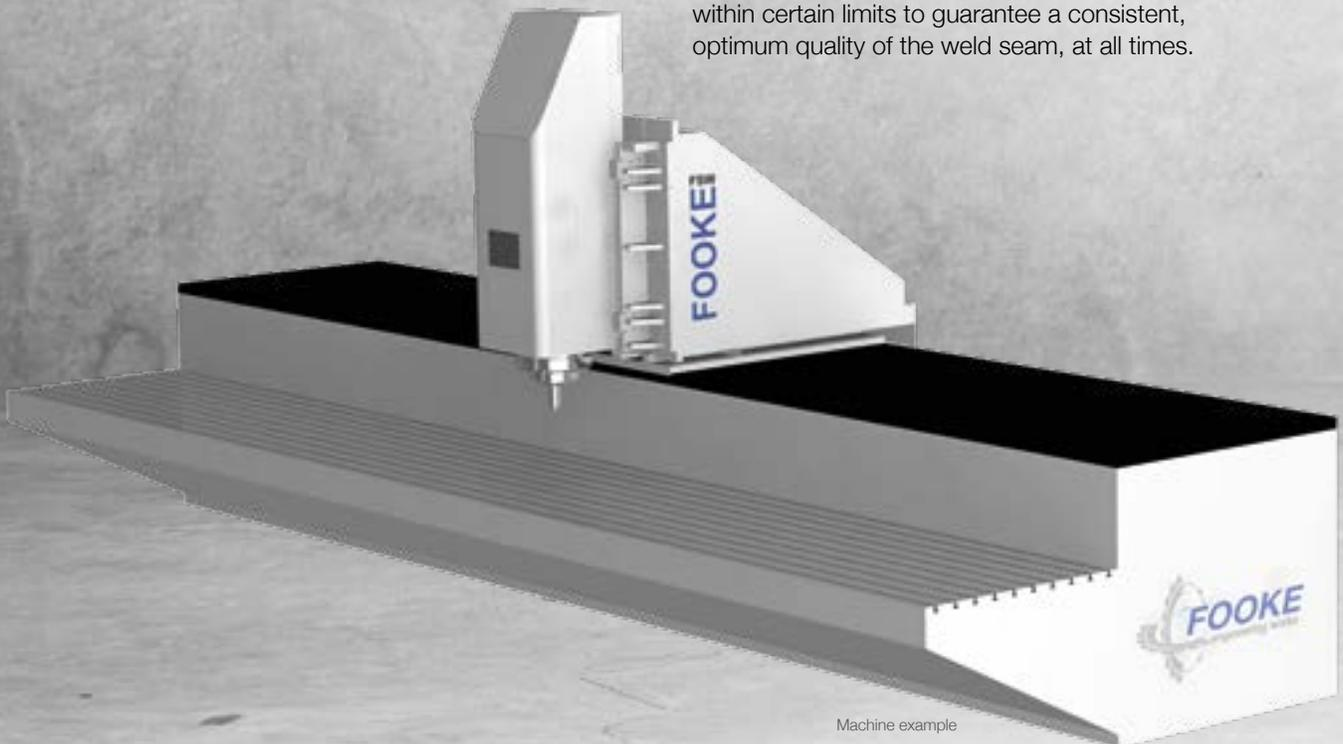

Machine example

Technical data

	Traverse paths
X axis:	78.7" - 1,181.1" (2,000 - 30,000 mm)
Y axis:	19.7" (500 mm)
Z axis:	19.7" (500 mm)

Welding parameters

Welding depth:	up to 2.75" (70 mm)
Max. axial force:	approx. 22.481 lbf (100 kN)
Welding feeds:	up to 236.2"/min (6,000 mm/min)

Areas of application



Railway



Aerospace industry



Industrial plant engineering



Automotive industry



Mechanical engineering

FOOKE FSW 20 SHEET METAL JOINING SYSTEM

Friction Stir Welding Machine for Metal Sheets

The FOOKE FSW 20 is a 2-axis machine tool for the welding of flat sheets of aluminum. It was specifically designed for plates with a width of up to 10,000 mm.

Machine design

The structural components of a FOOKE FSW 20 are manufactured as extremely rigid, stress-relieved welded steel construction. The linear axes are equipped with hardened and ground linear guide elements and driven by recirculating ball screws. The plates are fixed by a hydraulic clamping system, specially developed for this purpose.

Control

The FOOKE FSW control system enables a simple and intuitive operation. The user interface is user-friendly, clearly displaying all important information and ensuring optimum control of the welding process.

All relevant parameters can easily be set up on the panel, e.g.

- welding force,
- rpm,
- welding speed,
- traverse paths,
- etc.

FOOKE FSW force sensor system

The FOOKE FSW force sensor system consists i.a., of a sensor unit integrated into the FSW spindle, which measures the axial force generated in the welding process. This ensures a constant force within certain limits to guarantee a consistent, optimum quality of the weld seam, at all times.



Machine example

Technical data

	Traverse paths
X axis:	up to 393,7" (up to 10,000 mm)
Z axis:	up to 3.9" (up to 100 mm)

Welding parameters

Welding depth:	up to 2.75" (70 mm)
Max. axial force:	approx. 22.481 lbf (100 kN)
Welding feeds:	up to 236.2"/min (6,000 mm/min)

Areas of application

-  Commercial vehicles
-  Silo construction
-  Facades
-  Mechanical engineering



FOOKE FSW 30 CYLINDER WELDING MACHINE

Friction Stir Welding Unit for Longitudinal Cylinder or Pipe Welds

The FOOKE FSW 30 is a 2-axis machine tool for welding bent or rolled cylinders, tubes of aluminum or similar materials. It can be ideally applied for the longitudinal welding of round and oval workpieces with a length of up to 10,000 mm and a diameter of up to 2,600 mm.

Machine design

The structural components of the FOOKE FSW 30 are manufactured as extremely rigid, stress-relieved welded steel construction. The linear axes are equipped with hardened and ground linear guide elements and driven by recirculating ball screws. The plates are fixed by a hydraulic clamping system, specially developed for this purpose.

Control

The FOOKE FSW control system enables a simple and intuitive operation. The user interface is user-friendly, clearly displaying all important information and ensuring optimum control of the welding process.

All relevant parameters can easily be set up on the panel, e.g.

- welding force,
- rpm,
- welding speed,
- traverse paths,
- etc.

FOOKE FSW force sensor system

The FOOKE FSW force sensor system consists i.a., of a sensor unit integrated into the FSW spindle, which measures the axial force generated in the welding process. This ensures a constant force within certain limits to guarantee a consistent, optimum quality of the weld seam, at all times.



Machine example

Technical data

	Traverse paths
X axis:	up to 393,7" (up to 10,000 mm)
Z axis:	up to 3.9" (up to 100 mm)

Welding parameters

Welding depth:	up to 2.75" (70 mm)
Max. axial force:	approx. 22.481 lbf (100 kN)
Welding feeds:	up to 236.2"/min (6,000 mm/min)

Areas of application



Commercial vehicles



Silo construction



Pipes



Mechanical engineering

EXPERIENCE THE PERFORMANCE LIVE DURING THE PROCESSING OF YOUR OWN COMPONENT.

In our technology and demonstration centre we offer you the opportunity to test the compatibility of your component with our machines in advance.

You would like to integrate FSW technology into your company, but are not sure how to combine the requirements of your production with the possibilities of automated welding processes?

Our application engineers will be happy to carry out geometry investigations, feasibility studies and welding tests on your workpiece with different welding strategies, according to your requirements.

Advantages of our demonstration centre:

- Execution of sample welds.
- Feasibility studies.
- Determination and optimization of parameters.
- Tool development and selection.
- Development of welding strategies.
- Production of test components.





„When we have customers on site for the first time and they see how their workpiece reacts in the machine and how time-saving and high-quality the welding process is, they are quickly enthusiastic. We want our quality to convince you.“

Sebastian Wevers, FSW application engineer



RELIABILITY THROUGH
OPERATIONAL TESTS



Machine example

RESEARCH & DEVELOPMENT FOR AEROSPACE: CAN FRICTION STIR WELDING REPLACE RIVETING OF FUSELAGE SHELLS?

Development of a 5-axis FSW process for joining of large-format aluminium sheets to an aircraft fuselage.

In a joint project with the renowned Technical University of Darmstadt and our valued customer AIRBUS Aerostructures GmbH, FOOKE has developed, designed and manufactured an innovative 5-axis FSW system together with a vacuum clamping device.

This system is used to weld spherically curved fuselage shells of the Airbus A321.

The „MeGRO“ research project, funded by the Niedersächsische Investitions- und Entwicklungsbank (Lower Saxony Investment and Development Bank), has shown that the conventional riveting process can be replaced by the FSW process. With this new FSW application, the weight of an aircraft can be significantly reduced by 1 kg per meter. This leads to a substantial saving in paraffin consumption, contributing to more environmentally friendly aviation.

Advantages:

- No sealant
- No drilling chips
- Less tool wear
- Lower energy consumption
- Lower fuel consumption
- Better aerodynamics
- Reduction of cleaning work
- No rivet head maintenance
- Full recyclability of the longitudinal seam
- Elimination of titanium fasteners

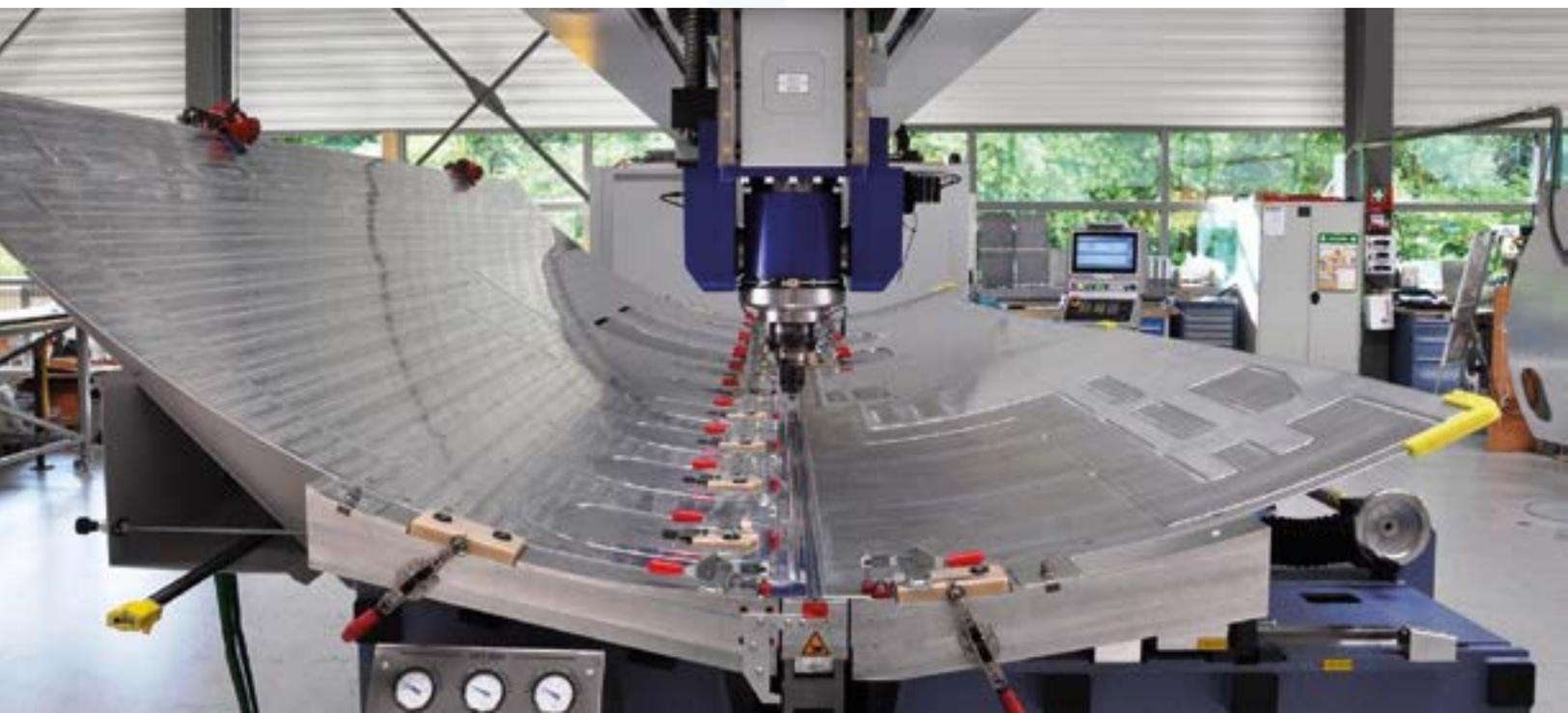

WE ARE ALWAYS THERE FOR YOU WORLDWIDE WITH OUR SERVICE

With its comprehensive range of services, our service team is a reliable partner for the entire service life of your plants.

From commissioning and remote maintenance to fast delivery of original spare parts.

For an uninterrupted workflow it is important to solve any problem in the fastest reaction time possible. For this reason, our service department is available around the clock on request. Qualified service staff will receive your damage reports and initiate all necessary measures to remedy machine downtimes as quickly as possible.

During maintenance and repair training courses, we also provide valuable knowledge to make optimum use of machine running times.

With the classic operator training and production support, we qualify your personnel with the purchase of a new machine.

Whether as regular training units or intensive workshops - within the FS Training the training contents are compiled and prepared according to customer requirements and carried out by our experts.

We combine short response times, high machine availability and reduced warehousing costs with professional support to your advantage - worldwide with local partners.

NEAR YOU WORLDWIDE



Find the contact person for your region.

Head office
Subsidiaries
Sales partners
Service sites

FSW-KOMPETENZZENTRUM

We work in long-term and close cooperation with the SLV Berlin-Brandenburg.

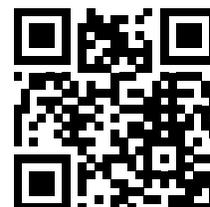



FOOKE GmbH
Raiffeisenstraße 18-22
46325 Borken

+49 (0) 2861 8009 - 222
sales@fooke.de

www.fooke-machines.com

04/2024